



FDB181C Detector Base Product Manual

Overview

The FDB181C detector bases is a universal base. It's fixed on fire detection site and used for installations of FD181C series detectors:

- FDO181C smoke detector
- FDT181C heat detector

Characteristics

- Universal bases, applicable to both surface install and conceal install
- Large opening in the detector base for easy cable insertion
- Adopt environmental friendly material

Installation

The installation of a base should strictly follow the engineering design drawings. The bases should be evenly distributed.

Procedure of installation:

1. Insert the cables through the base and connect them to the terminals.
2. Fix the base to the ceiling with screws.

Note:

- The detector should be installed after the construction has been finished.
- In order to ensure the reliability of the connection between the base and the detector, please do not use U-type terminals.
- Twisted-pairs with the wiring requirement of 1.0~1.5mm² are recommended.

Dimensions

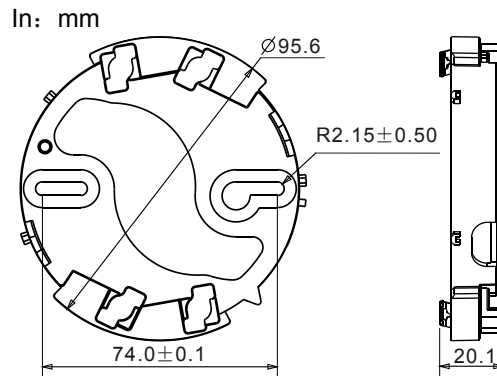

Electric connection

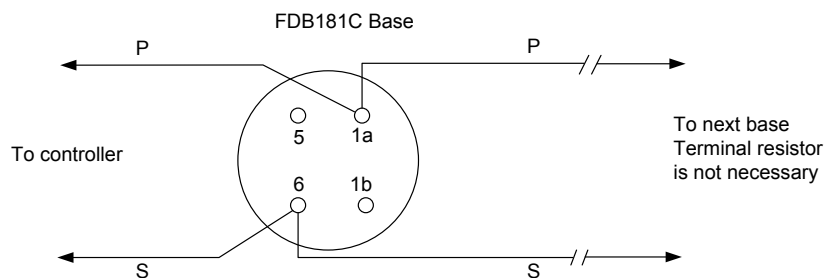

Technical data

Connecting terminals	1.0 ... 1.5 mm ²
Operating temperature	
Storage temperature	
Humidity	According to data of detectors
Protection category EGB4208-93	
Color	White, RAL 9010

Details for ordering

Type	Material No.	Part No.	Designation	Weight
FDB181C	S54320-F1-A1	100856213	Detector base	0.027 kg